

# TRAVELLER

LIGHT WEIGHT FLOORING ASSEMBLY  
FOR RAIL PASSENGER CARS



INSTALLATION GUIDELINES

**Gerflor**<sup>®</sup>  
theflooringgroup

**INTRODUCTION ..... 4**

**STEP 1: PREPARATION & INSPECTION..... 4**

1.1 Goods on arrival..... 4

1.2 Storage & Handling ..... 5

1.3 Subfloor preparation ..... 5

1.4 Floorcovering inspection ..... 5

1.5 Adhesive selection ..... 6

**STEP 2: ROLL LAYOUT & CUTTING ..... 6**

2.1 Cutting to vehicle size ..... 6

2.2 Pre-cut shipsets ..... 6

**STEP 3: ADHESIVES & INSTALLATION..... 7**

3.1 Traveller Self-adhesive ..... 7

3.2 Water-based acrylic adhesives ..... 7

3.3 MSP / PU adhesives ..... 7

**STEP 4: LOGOS & INSTALLATION..... 8**

**STEP 5: HOT WELDING PROCESS FOR FLAT, COVERED & VERTICAL AREAS ..... 9**

5.1 Treatment of seams using hot welding process ..... 9

5.2 Hot welding tools ..... 10

5.3 Hot welding process ..... 10

**STEP 6: GERSEAL 11 MASTIC SEALANT ..... 12**

**STEP 7: CLEANING (refer to Traveller Cleaning Guide) ..... 12**

**ANNEX: TRAVELLER RECOMMENDED TOOL LIST ..... 12**

## INTRODUCTION

Traveller floorcoverings are designed to meet all global transportation industry requirements. To obtain optimum performance from Traveller floorcoverings follow carefully our installation recommendations.

Important: failure to install Gerflor Transport products correctly will affect the product guarantee.

### PRODUCT LIABILITY

Gerflor shall not be liable for any injury, loss or damage, whether direct, indirect, special, incident or consequential, arising out of the furnishing of, the use of, or any inability to use the Tarabus materials provided therefrom. The remedies of the purchaser set forth herein are exclusive, and the liability of Gerflor with respect to any sale or anything done in connection therewith, whether in contract, in tort, negligence, under any warranty or otherwise, shall not, except as expressly provided herein, exceed the cost of replacement of Tarabus materials upon which such liability is based. Buyers assume all risks and liability for damage to persons or property resulting from buyer's use of the material.

## STEP 1: PREPARATION & INSPECTION

### 1.1 - GOODS ON ARRIVAL

Goods will arrive on pallets in one of two configurations:

- Horizontal position in a pyramid format
- Vertical position



Horizontal Transportation



Vertical Transportation

### 1.2 - BEFORE STORAGE AND HANDLING

Before storage, goods must be removed from the pallets, and all outer transparent wrapping (stretch film) and belts should be taken off.

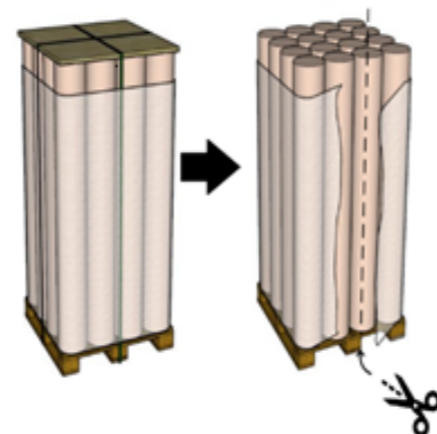

Cut and open the stretch film and the belts

## STEP 1: PREPARATION & INSPECTION

### 1.3 - STORAGE & HANDLING

- Traveller Flooring must be stored unopened in its original brown paper wrapping or Kit box. The warehouse should be fit for purpose with no potential of rain/snow ingress through the roof or walls.
- Traveller Flooring should be stored vertically to reduce the appearance of pressure marks. Ideally on a pallet to stop direct contact with damp concrete or water ingress into the building at floor level.
- Traveller Flooring can also be stored horizontally on a high density foam pad. Each roll must be stored individually on the rack and not in contact with other rolls. Gerflor do not recommend storage on the top level of a rack that is in close proximity to the roof as this can cause inconsistent temperature spread through the roll.
- Important note:

- If storage time exceeds 6 months, it is recommended that Traveller Flooring with self-adhesive is not exposed to temperatures exceeding +50° Celsius or below 0° Celsius.
- Rolls should be transported by use of a hand truck or with a forklift
- Rolls should be removed from packaging, unrolled and laid flat 24 hours prior to installation. Relaxation time can be reduced if customers are able to utilise heated tables, ovens or lamps

### 1.4 - SUBFLOOR PREPARATION

#### 1.4.1 - Subfloor preparation

For all subfloor types make sure surfaces are clean, smooth, flat, dry and free from contamination. Cleaning of the subfloor should be in accordance with the vehicle manufacturers Standard Operating Procedure.

All cleaning products used should be compatible with the surface being cleaned.

#### 1.4.2 - Vehicle inspection

Before installation, carry out a vehicle inspection. Check the subfloor is properly fixed and flat according the subfloor manufacturer recommendations.

#### 1.4.3 - Timber subfloors

The subfloor panels should be securely fixed in place as per the specifications of individual vehicle manufacturers.

All joints between panels should be sanded and filled to ensure a smooth transition.

#### 1.4.4 - Metal subfloors

The subfloor panels should be securely fixed in place as per the specifications of individual vehicle manufacturers

Degrease and in case of corrosion abrade the metal floors.

All joints between panels should be sanded and filled to ensure a smooth transition.

### 1.5 - FLOORCOVERING INSPECTION

- See Label Description.
- Check product, colour, and batch reference before installation.  
**Use one batch per car.**
- For traceability purposes, the batch number should be kept.



Vertical Storage



Horizontal Storage



Handling



Traveller Installation SNCF Trains



# INSTALLATION GUIDELINES

## 1.6 - ADHESIVE SELECTION

- Choosing the correct adhesive will ensure that the installed materials will perform as expected in service.
- You can find below Gerflor recommended adhesives. All the adhesives listed have been laboratory tested on timber and steel subfloors for their compatibility with Gerflor flooring materials. Gerflor recommends that the adhesive manufacturers are consulted to ensure that the correct adhesive is specified for the specific project.

RECOMMENDED ADHESIVE	FLEXIBILITY [grade from 1 to 5]	BOND STRENGTH [grade from 1 to 5]	CURING TIME [hour]	REPOSITIONING
TRAVELLER Self-adhesive	5	4	None (0 hours)	Possible prior to rolling
MAPEI G19 FR (PU)	3	4	12 hours	Up to 4 hours
UZIN KR 430 (PU)	2	5	12 hours	Up to 4 hours
F.BALL 73+ (MSP)	4	3	2 hours	Up to 90 mins
BOSTIK IR703/07 (MSP)	4	3	12 hours	Up to 4 hours



## STEP 2: ROLL LAYOUT & CUTTING

### 2.1 - CUTTING TO VEHICLE SIZE

Review the floor plan for the individual car, establish the direction that the pieces will be installed in and define any weld position. Lay out the floorcovering on a clean, dry and flat working area. A template can be used to avoid cutting errors.

To optimize the installation process: Pre-cut and Pre-welded kits can be produced specifically to the individual requirements of the client. Please ask your sales representative for more information.

- Mark the lines to be cut-off or use a pattern as a template. Use a Delphin knife [E6000002] and a straight edge for cutting the material.
- Whether the material is to be installed flat or covered up the side of the vehicle Gerflor recommends that a minimum of 5 cm extra material is allowed on each end (10 cm overall) to ensure the piece is long enough and can be trimmed comfortably.
- When Joining Factory Edges – Leave a gap of 1 ± 0.5 mm maximum.
- Cut seams using any of the following methods:
  - Overlap and trace,
  - Underscribe (recess scribe method).

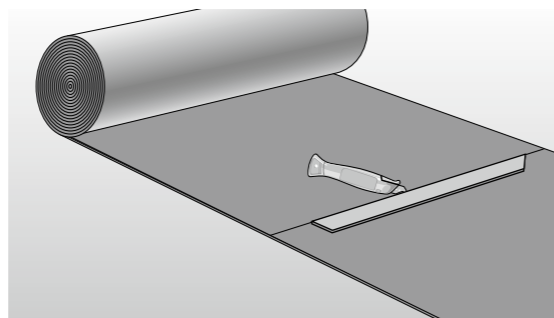

When installing designs of a geometric nature, it is important to ensure that the material is installed straight. Particular attention should be paid to release cuts on external corners when trimming the waste for positioning. Failure to not cut the material as close as possible to the base of the external angle may cause deformation of the design. This is due to excess material being forced around the base on the external corner. When making release cuts or removing excess waste, always cut the material from the backside.

### 2.2 - PRE-CUT SHIPSETS

Gerflor in-house cutting department is able to supply pre-cut pieces to specific dimensions from plans supplied by the customer.



# INSTALLATION GUIDELINES



## STEP 3: ADHESIVES & INSTALLATION

We propose 3 types of installation process depending on the adhesive solution.

### 3.1 - TRAVELLER SELF-ADHESIVE

**TIP:** have a look at our Youtube video: [TRAVELLER KIT SYSTEM](#)

- In case of rolls, cut the flooring to the area size.
- Lay out the floor into the car.
- Fold back one half.
- Use a hooked blade [E7520001] to cut the protective layer from the underside floor covering. Take care not to damage the floorcovering backing.



- Pull off the protective layer from the exposed half area.
- Position the material into the targeted location and make sure the air is expelled out towards the edges.
- Repeat steps 3 to 6 to the remaining half.



### 3.2 - WATER-BASED ACRYLIC ADHESIVES

Follow the adhesive manufacturer's instructions regarding subfloor types, correct trowel / blade size, open times, temperature and humidity conditions.

- Cut the flooring to the size required.
- Fold back the flooring halfway.
- Apply the adhesive to the subfloor. Use the recommended trowel and blade [Aluquick Spreader E6130001].
- Allow the adhesive to tack off (this will vary depending on temperature and subfloor absorbency).
- Place flooring into adhesive and smooth manually then use a pressure-roller.
- Repeat this process with the other half.
- Follow the manufacturer's guidelines for waiting times for welding and foot traffic.

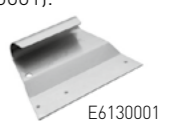

### 3.3 - MSP / PU ADHESIVES

Follow the adhesive manufacturer's instructions regarding subfloor types, correct trowel / blade size, open times, temperature and humidity conditions.

- Cut the flooring to the size required.
- Lay out the floor into the car.
- Fold back the flooring halfway.
- Apply adhesive to subfloor. Use the recommended trowel and blade [Aluquick Spreader E6130001].
- Position floor product on adhesive and roll strongly to ensure right contact with subfloor.
- Repeat this process with the other half.
- Weights will be required to ensure the floor remains flat during curing.
- Wait for the adhesive to fully cure before applying pressure and heavy loads on the floor.



With any adhesive system used to install the floorcovering, Gerflor always recommend the use of a cork press [E6640001] or cork broom [E6640002] to ensure a good initial contact and the expulsion of any air from beneath the product. On completion of the installation, the whole floor area should be rolled in the length and the width of the vehicle with a pressure-roller of 50 kg [E6320001].

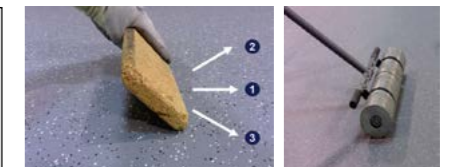



## STEP 4: LOGOS & INSTALLATION

For complete watertightness, subfloor protection and high in-service performance Gerflor recommends the use of our laminate backed logos. It can be installed with self-adhesive backing or traditional glue.

**TIP:** have a look at our Youtube video: [Implantation Logo - Installation Guidelines](#)

**Note:** the logo on laminate backing should not be folded or rolled.



- Position and mark where the pre-cut logo will be located.



- Remove the protective layer of the self-adhesive logo or apply the traditional adhesive on subfloor.



- Once the logo is in place, press it with a cork press, install the floorcovering over the installed logo, and press it too, to optimize adhesion.  
**Recommended tools:** Cork press [E6640001] or Cork broom [E6640002].



- Using a pressure roller, roll around the edge of the logo to identify its position.  
**Recommended tool:** Internal angle roller [E6600001].



- Cut the waste from above the logo so that the main flooring material overlaps the logo by 5 cm max, leaving a 1 mm space all around.  
**Recommended tool:** Delphin knife [E6000002].



- Using a recess scriber. Scribe around the logo while the pin in the scriber transfers and marks the surface of the main flooring material.  
**Recommended tool:** Recess Scriber [E8220002].



- Carefully follow the scribed line with the knife. This will provide a clean line between logo and material.



- Use a Linea Groover to create the groove between logo and main material. You may use our Triangular Groover to refine the groove.  
**Recommended tools:** Linea Groover [E8060001], Triangular Groover [E8000004].



- Hot weld the logo to the main flooring material using CR50 (Traveller Classic) or CR40 (Traveller Evolution and Traveller Discovery).  
**Recommended tools:** Welding Gun Leister Triac'S [E8090002], Anti-Glaze Rapid Nozzle 4-5mm [E8100002].

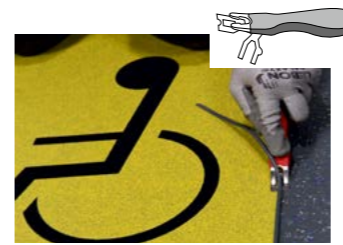

- Using the Mozart 2 in 1 Trimming Knife, with the 0.7 mm spacer, carry out the first trim of the weld cord. Do not carry out the second trim until the weld is completely cold.  
**Recommended tool:** Mozart 2 in 1 Trimming Knife [E8300002].

- As final step, you may use a pressure-roller of 50 kg [E6320001] to optimize adhesion (rolling in the length and in the width).
- When installing self-adhesive flooring around a logo, before installing the flooring, cover the installed logo with a scrap piece of lining paper and secure at the perimeter with masking tape. This stops the self-adhesive layer sticking to the logo.



## STEP 5: HOT WELDING PROCESS FOR FLAT, COVERED & VERTICAL AREAS

### 5.1 - TREATMENT OF SEAMS USING HOT WELDING PROCESS

Hot Welding should only be completed after full cure of the adhesive. In case of self-adhesive, the welding can be completed right after the installation.

**CR50 by Gerflor:** Traveller Classic flat weld

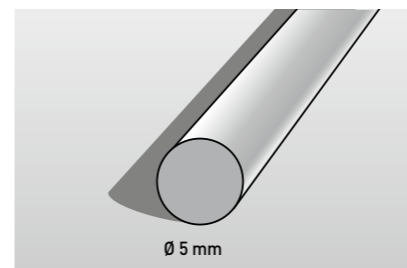

**CR40 by Gerflor:** Traveller Evolution and Traveller Discovery flat weld

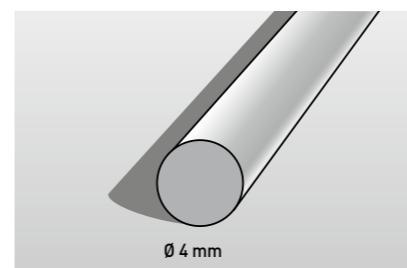



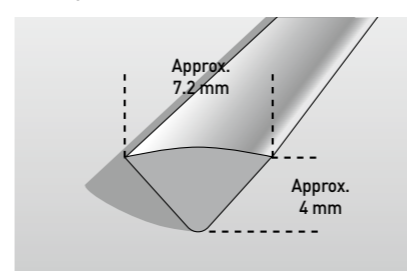

**CA72 by Gerflor:** Traveller Classic corner weld



# INSTALLATION GUIDELINES

## 5.2 - HOT WELDING TOOLS

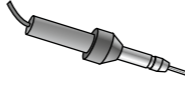
You can find below the recommended hot welding tools, divided into the 3 welding steps:

STEP	TOOL	PART NUMBER	
GROOVING	LINEA GROOVER	E8060001	
WELDING	ANTI-GLAZE RAPID NOZZLE 4-5 MM (flat weld)	E8100002	
	CA72 SPEED NOZZLE WITH WHEEL (Traveller Classic corner weld)	E8100008	
	HOT WELDING GUN LEISTER TRIAC-S 220 V	E8090002	
TRIMMING	MOZART 2 IN 1 TRIMMING KNIFE	E8300002	

## 5.3 - HOT WELDING PROCESS

**TIP:** have a look at our YouTube videos: [Hot Welding - Installation Guideline](#) and [Hot Welding for Traveller Evolution - Installation Guideline](#)

### 5.3.1 - Preparation

- Ensure that the gap between the adjoining sections of the flooring to be elded does not exceed  $1 \pm 0.5$  mm.
- Seams must be grooved and clear of debris before welding.
- Ensure the nozzle is clear of debris.
- Turn on the gun adjusting the temperature dial to between 4.5 & 5 and leave to heat for 5 minutes before use.

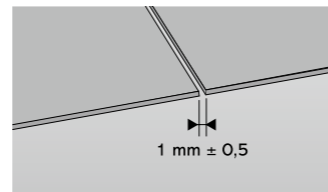

**Tips:** Test a weld on a small piece of waste flooring before starting welding in the vehicle. Weld rod should fuse without burning.

### 5.3.2 - Grooving

Various tools are available to produce a good quality and consistent groove. Gerflor recommends the Linea Groover (E8060001).

It's necessary to groove  $2/3^{\text{rd}}$ s thickness of the wearlayer and to have a gap between the edges of  $1 \pm 0.5$ mm. On the top, the gap after grooving is  $3 \pm 0.5$  mm.



Linea Groover

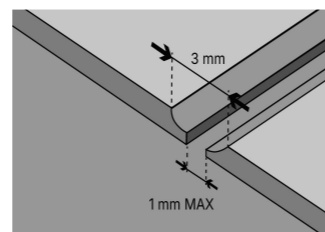

# INSTALLATION GUIDELINES

## 5.3.3 - Welding

For flat welding, use a CR50 (Traveller Classic) or CR40 (Traveller Evolution and Traveller Discovery) welding rod.

- Cut the colour matching weld cord to the required length.
- Hold the hot welding gun Leister Triac-S (E8090002) at an upright angle and combine with constant pressure and speed as you progress along the weld. We recommend the use of our Anti-glaze Rapid Nozzle 4-5 mm (E8100002).



For corner weld (Traveller Classic only), use a CA72 welding rod.

- Cut the colour matching weld cord to the required length.
- Hold the Hot Welding Gun Leister Triac-S (E8090002) with an angle that allows the rod to cover the base of the corner and combine with constant pressure and speed as you progress along the weld. We recommend the use of our Speed Nozzle with wheel (E8100008).



## 5.3.4 - Trimming

Trimming the weld cord should be completed in two stages.

- Trim the weld while still warm using the Mozart 2 in 1 trimming knife (E8300002) with the 0.7 mm spacer in place. This action will allow the weld cord to contract and relax. Retract the 0.7 mm spacer.
- Trim the remaining weld to produce a neat flush finish. **THIS PROCESS SHOULD ONLY BE COMPLETED WHEN THE WELD IS COMPLETELY COLD.**

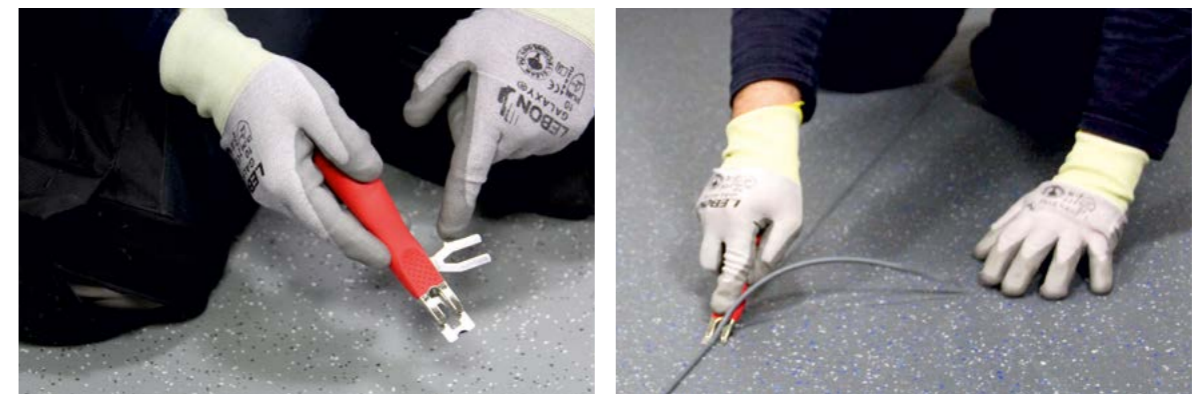

For finishes, move aside the trimming guide. Don't forget to regularly change the blade.

# INSTALLATION GUIDELINES

## STEP 6: GERSEAL 11 MASTIC SEALANT



Gerseal 11 can be applied to vertical junctions, perimeters and exposed sides to produce a fully watertight junction.

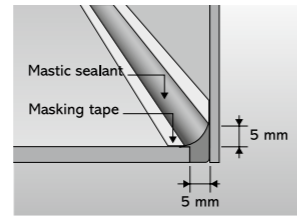

Apply a 5 mm bead and use masking tape to ensure a neat finish when smoothed.  
Skin Off – 40 mins  
Full Cure 12 -24 hours\* (T°/RH)  
1 x 310ml Cartridge will cover 10 linear mtrs

## STEP 7: CLEANING (refer to Traveller Cleaning Guide)

For further information, please contact your sales rep.  
For technical advice please contact: [andrew.sedman@gerflor.com](mailto:andrew.sedman@gerflor.com)

## ANNEX: TRAVELLER RECOMMENDED TOOL LIST

PART NUMBER	DESCRIPTION	GENERAL INSTALLATION	WELDING	LOGO	SELF-ADHESIVE
E8360001	LEISTER CARRYING CASE				
E6000002	DELPHIN KNIFE (1 unit)	✓	✓	✓	✓
E7510003	100 STRAIGHT BLADES	✓	✓	✓	✓
E7520001	100 HOOKED BLADES	✓	✓	✓	✓
E6600001	INTERNAL ANGLE ROLLER	✓		✓	✓
E6640001	CORK PRESS with rounded edges 300 x 120 x 250 mm	✓		✓	✓
E8000004	TRIANGULAR GROOVER		✓	✓	
E8060001	LINEA GROOVER		✓		
E8300002	MOZART 2 IN 1 TRIMMING KNIFE		✓		
E8600001	WIRE BRUSH FOR NOZZLE DUCT		✓		
E8100008	CA72 SPEED NOZZLE WITH WHEEL		✓ <i>Traveller Classic only</i>		
E8100002	ANTI-GLAZE RAPID NOZZLE 4-5 mm		✓		
E8090002	HOT WELDING GUN LEISTER TRIAC-S 220 V		✓	✓	

# INSTALLATION GUIDELINES

OPTIONAL					
PART NUMBER	DESCRIPTION	GENERAL INSTALLATION	WELDING	LOGO	SELF-ADHESIVE
E3060001	CARPET CLAW	✓			✓
E6150004	CONVEX RULER 210 x 8 cm FLEXIBLE STEEL	✓	✓		✓
E6130001	ALUQUICK SPREADER	✓		✓	
E6310001	SPARE BLADE A1 280 mm (10 units)	✓		✓	
E6310003	SPARE BLADE A2 280 mm (10 units)	✓		✓	
E6310007	SPARE BLADE B1 280 mm (10 units)	✓ <i>Traveller Evolution Traveller Discovery</i>			
E8220002	RECESS SCRIBER	✓		✓	✓
E6640002	CORK BROOM BALAI LIEGE	✓		✓	✓
E6320001	PRESSURE-ROLLER (50 kg)	✓		✓	✓
E8060003	MASTER TURBO GROOVER		✓	✓	
E8610001	BALL PRESSURE SHAFT Ø 13 mm		✓		
E8100001	PUSH FIT NOZZLE HOLDER NOZZLE 4-5 mm		✓		
E8110002	RAPID NOZZLE MUSHROOM SH. ROD		✓		
E8100009	ROLLER TURBO NOZZLE		✓		
E8000001	ROUNDED GROOVER		✓	✓	
E8190001	SPARE BLADES (10 units) for Rounded Groover		✓	✓	
E8320001	TRIMMING GUIDE		✓		
E8040001	SPARE BLADES MOZART (5 units)		✓	✓	
E8080001	TRIMMING GOUGE + 1 BLADE		✓		
E8300003	QUARTER MOON TRIMMING KNIFE		✓		
E8330001	LEATHER POUCH - 1/4 MOON KNIFE		✓		
E8120001	2 ROUNDED BLADES 6 mm		✓		
E8120003	2 FLAT BLADES		✓		
E8120004	2 POINTED BLADES		✓		



# TRAVELLER

LIGHT WEIGHT FLOORING ASSEMBLY  
FOR RAIL PASSENGER CARS

43, Boulevard Garibaldi  
69170 Tarare - France  
Tel.: +33 4 74 05 40 00  
Fax: +33 4 74 05 06 83  
Email: [traveller@gerflor.com](mailto:traveller@gerflor.com)  
[www.travellerbygerflor.com](http://www.travellerbygerflor.com)



**Gerflor**<sup>®</sup>  
theflooringgroup